



DX-1002-T

The DX modular housing arrangement offers a flexible and space conscious solution to integrate our innovative DXO Cartridge in to both new and existing systems. The Delta-Xero system can be configured up to 12 cartridges in parallel as a single unit in a compact and easily maintainable layout.

The unit can be supplied with a number of standard options to provide an effective fluid conditioning and monitoring package to suit the majority of systems. The flexibility of the unit allows tailoring to customer's specific requirements.



DX1002-T

| | |
|-------------------------|--------------------------------|
| Drive Input | Electric or Pneumatic |
| Connection Ports | 3/8" BSP In & Out |
| Flow Indicator | Visual |
| Suggested System Volume | Up to 4000l @ 32cSt |
| Flow Rate | 2 lpm @ 32cSt |
| Particulate Removal | From 0.1 μ |
| Weight | 25 kg |
| Dimensions | H 916 mm x D 300 mm x L 550 mm |
| Material | SS316 |
| DXO Cartridge QTY | 2 |

© 2021 Delta-Xero All Rights Reserved. All information contained in this publication is indicative only and may be subject to change without prior notice.



General Arrangement

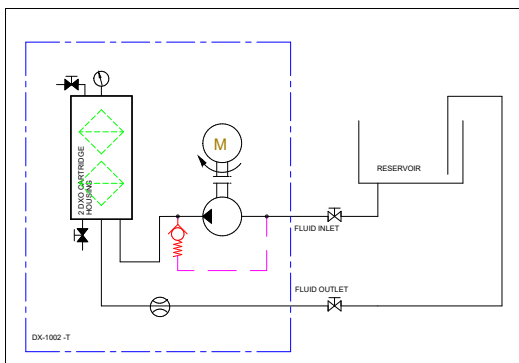
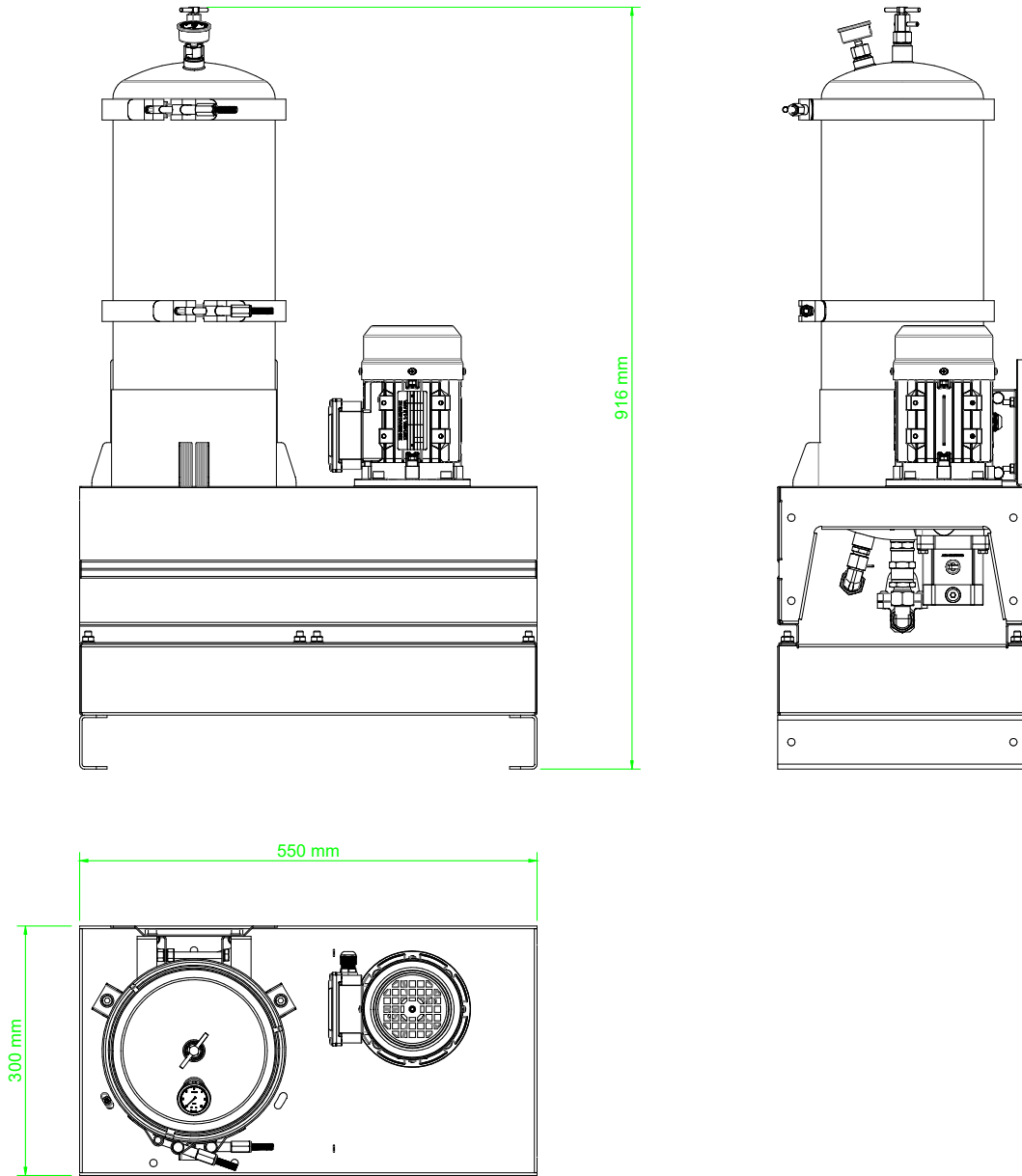

DXO Cartridge

Contamination capacity: 1955 g, 0.1 micron

Water absorption, free and bound: 2600ml

Material Insert: PP Cellulose mix

