

# FM090 Centrifuge

## Technical Data



### BENEFITS

- Cleaner oil and extended oil life
- Lengthens service intervals
- Reduces engine wear
- Enhances long-term preventative maintenance
- Reduces maintenance costs
- Cuts waste disposal costs
- Reduces application down time
- Maximises in-service time for vehicle/engine/machine
- Reduces total cost of ownership
- Helps ensure clean combustion and fuel efficiency
- Supports engine technology for the reduction of exhaust emissions (e.g. exhaust gas recirculation)
- Fast return on investment
- Cleanable metal rotor

### DIMENSIONS

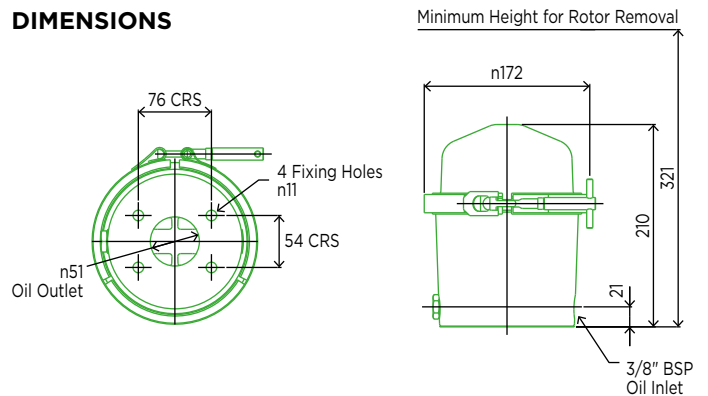

<b>Model</b>	<b>FM090-31</b>
<b>Part number</b>	68 991 42 101
<b>Oil inlet thread</b>	3/8" B.S.P.*
<b>Cut Off Valve (C.O.V.) ratings</b>	1.3 bar*
<b>Net weight</b>	3.5 kg
<b>System capacity</b>	15 – 90 litres
<b>Rotor dirt capacity</b>	0.9 litres
<b>Rotor oil capacity</b>	1.125 litre
<b>Minimum oil feed pipe size</b>	Ø 9.5 mm internal
<b>Minimum oil drain pipe size</b>	Ø 38 mm internal

\*Can be tailored to suit customer requirements  
Other features can be included to suit specific customer requirements

### PERFORMANCE CURVES

Typical Rotor Performance for SAE 30 Oil @ 100°C

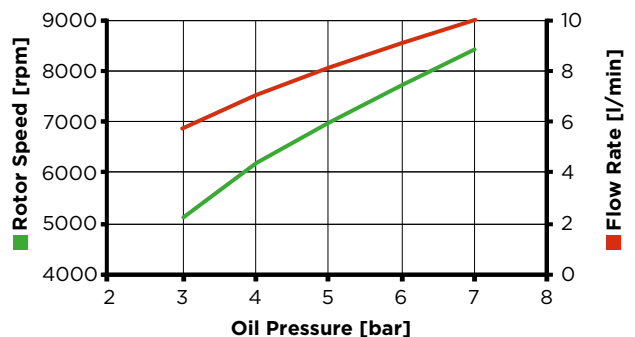

Authorised Distributor



t: +44 1264 860186  
e: spares@simplexturbulo.com

STC is a member of SIMPLEX ENGINEERING GROUP

